

## Subsea Full HD PoE Network Camera

Max 100M Subsea 4x Zoom Smart LED



### **iAQUA-100Z**

Subsea Full HD PoE Network Camera

## Key Features

- Full HD 2Mega Pixel PoE Network
- Underwater Up to 100meter, 24/7 365day 40meter
- IP68 Protection Degree
- Smart White LED / Brightness Control
- AISI 316L Stainless Steel / Tempered Glass
- Subsea Specialty Armored Cable (20meter, 50meter 100meter)
- 4x Zoom Lens / 3.0~12mm Motorized Lens
- 1/2.8" Sony STARVIS CMOS Sensor
- 2MP Full HD(1920 x 1080) / 30fps
- Multi Video Compression : H.264 / H.265 / MJPEG
- 0.03 Lux (IR LED Off), 0 Lux (IR LED On)
- True Day & Night / True Wide Dynamic Range
- ONVIF Support (Profile-S)
- **Application Market**
  - Marine, Offshore, Aquatic Ecology/Environment, Swimming Pool, Underwater drone
  - Fish farm, Water and sewage facilities

## CAMERA SPECIFICATION

Model No	iAQUA-100Z
Image Sensor	1/2.8" Sony STARVIS CMOS Sensor
Active Pixel	1,945(H) x 1,097(V) / 2.13 Megapixels
Lens	4x Zoom / 3.0~12 mm Motorized Lens / F1.6
Min. Illumination	Color : 0.03 Lux (IR LED Off), 0 Lux (IR LED On)
Day & Night	True Day & Night (Auto, Day, Night)
Electric Shutter Control	Auto, Suppress Rolling, Manual (1/30~1/30000 sec)
WDR	True WDR (ON/Off)
DNR	2 DNR, 3 DNR
Privacy Zones	Off / On (8 Programmable Zones)
Video Compression	H.264 / H.265 / MJPEG
Resolution	1920x1080, 1280x1024, 1280x960, 1280x720, 1024x768, 640x480, 320x240
Frame Rate	Max 30/25fps(NTSC/PAL)
Bit rate	32 Kbps ~ 8 Mbps (CBR/VBR)
Video Quality Control	H.264/H.265 (Bitrate Control), MJPEG (Quality Level Control)
Video Streaming	Triple Stream (H.264/H.265/MJPEG), RTP/RTSP, Unicast RTP, Multicast RTP
User	Max 10 User
Connector	Ethernet 10/100 Base-T(RJ-45)
IP	IPv4 / IPv6
Network protocol	TCP/IP, UDP/IP, RTP, RTSP, RTCP, NTP, HTTP DHCP, FTP, SMTP, DNS, DDNS
ONVIF	Profile-S
Power	PoE Class 3(IEEE 802.3af)
Light	White LED, Bright Control , On/Off
Cable	Armored Cable for Subsea , 20meter / 50meter / 100meter
Protection Degree	IP68 (Max 100M underwater)
Material	AISI 316L Stainless Steel / Tempered Glass
Operating Temperature/Humidity	-25°C ~ +55°C / Less than 95% RH
Size	Ø92 x 188 mm
Weight	3.0 Kg

## BRACKET TYPE A

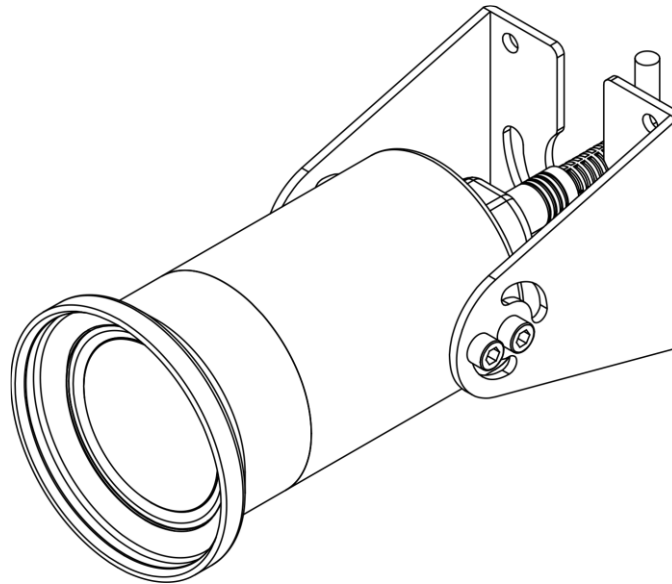

## BRACKET TYPE B

